

# The Power of Innovation and Automation

Interior Health Laboratory Sustainability Solutions

Dr. Denis Bonin - IH Medical Director  
Joanne Isber - Program Director

# Land Acknowledgement

---

Interior Health would like to recognize and acknowledge the traditional, ancestral, and unceded territories of the Dǎkelh Dené, Ktunaxa, Nlaka'pamux, Secwépemc, St'át'imc, Syilx, and T̓silhqot'in Nations where we live, learn, collaborate and work together.



# Increasing Pressures

IH Lab Vacancy Rate = 15%  
107 postings equating to 94 FTE

Unprecedented pressures on Lab, such as labour shortages and workload demand from BC's rapidly aging population, has made the move to Automation a necessity for the sustainability of Lab services

## LABOUR SHORTAGES

[Canadian Institute for Health Information data](#) states **approximately 400 additional student seats** are required by medical laboratory technologist programs in Canada to offset retirements

## AGING POPULATION

The 2021 Canadian Census found that the number of seniors in BC surpassed **1 million** for the first time ever – making up **20.3%** of the population

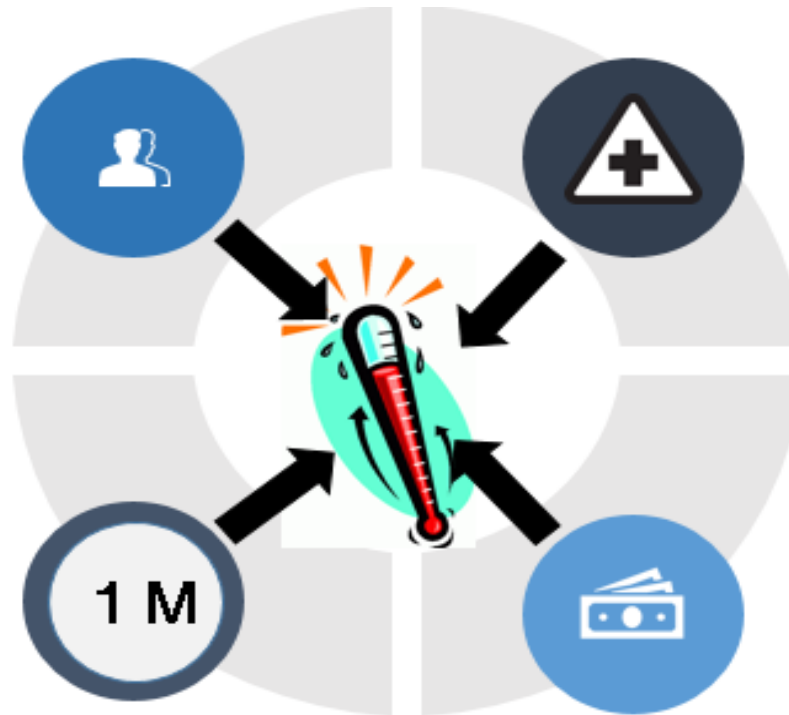

## ERROR AND RISK

Increase workload with reduced staffing can threaten successful completion of process. This can lead to **mistakes, biohazard risks** and increased staff **injuries**.

## COST

Reagents and consumables increased from 2020 to 2023 by 18%.  
Overtime 2020 \$3M vs 2023 \$5M  
Annual current growth of 3% (642 additional tubes/day)



# Digital Health Roadmap – Laboratory Systems

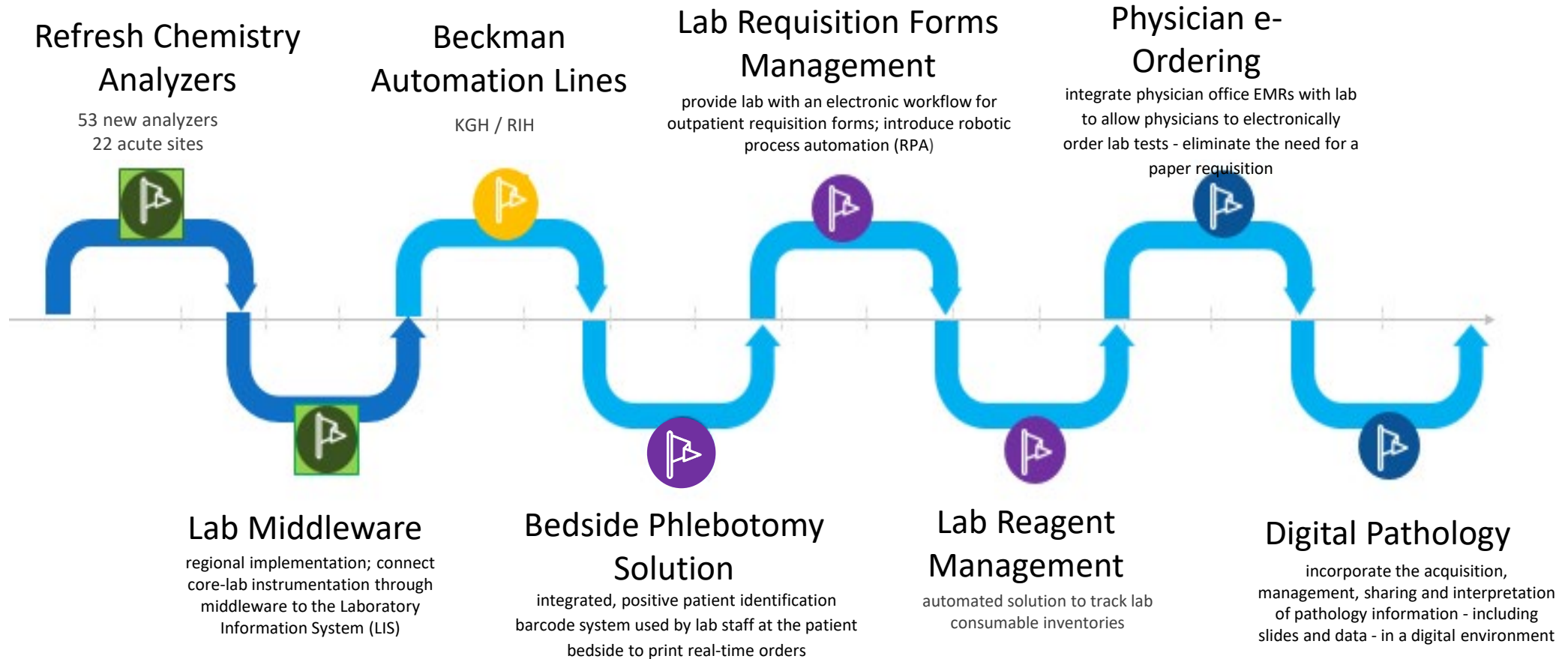

In Progress



In Planning



Subject to funding & resources



Provincial Integration

# Interior Health Innovative Solutions

## 1. Automation in high volume labs- Kamloops and Kelowna

## 2. Middleware- Regional solution

- a general term for software that "glues together" or bridges the gaps between separate, complex programs or systems.
- will inter-connect core-lab instrumentation and the Laboratory Information System (LIS); essentially functioning as a hidden translation layer,
- enables communication and data management between the two environments.





# Introducing the Beckman Automation Line

- ❑ Tracking system connects multiple laboratory instruments together allowing the sample to freely move from one instrument to another
- ❑ Barcode scanning determines testing and sample requirements including centrifugation.
- ❑ Completed sample is automatically stored in refrigerator and categorized for easy retrieval for any future testing required

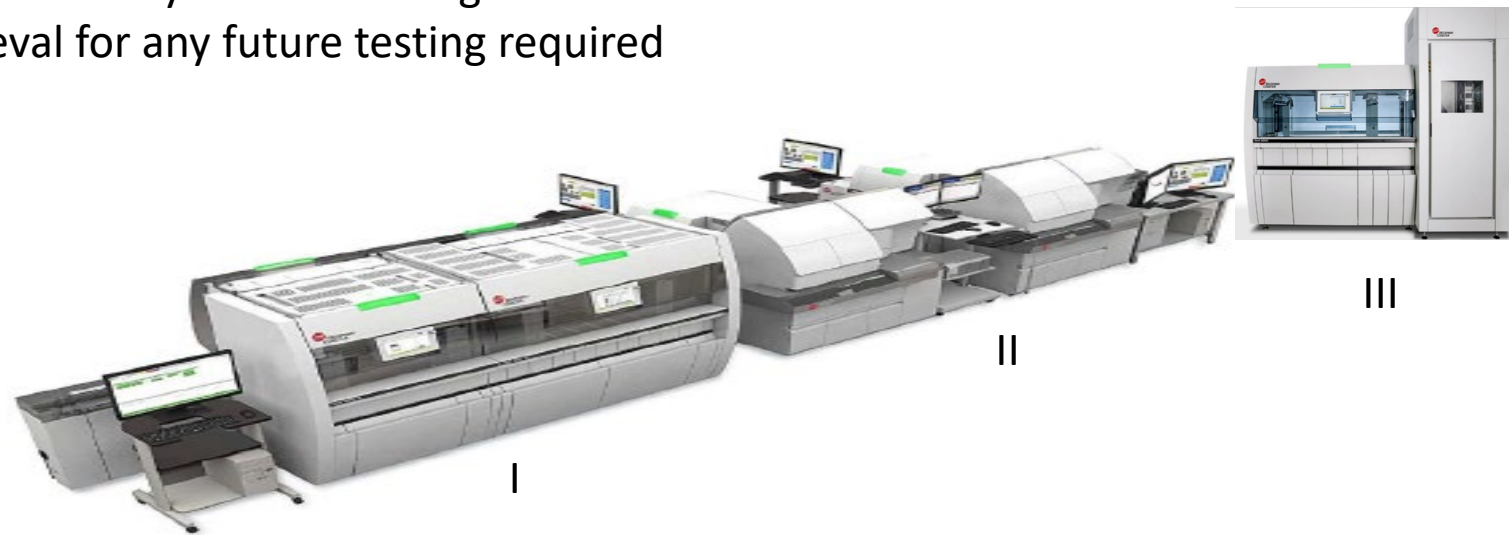

# Workflow Improvement

RIH Workflow  
#steps  
91 to 17

KGH Workflow  
# steps  
74 to 17

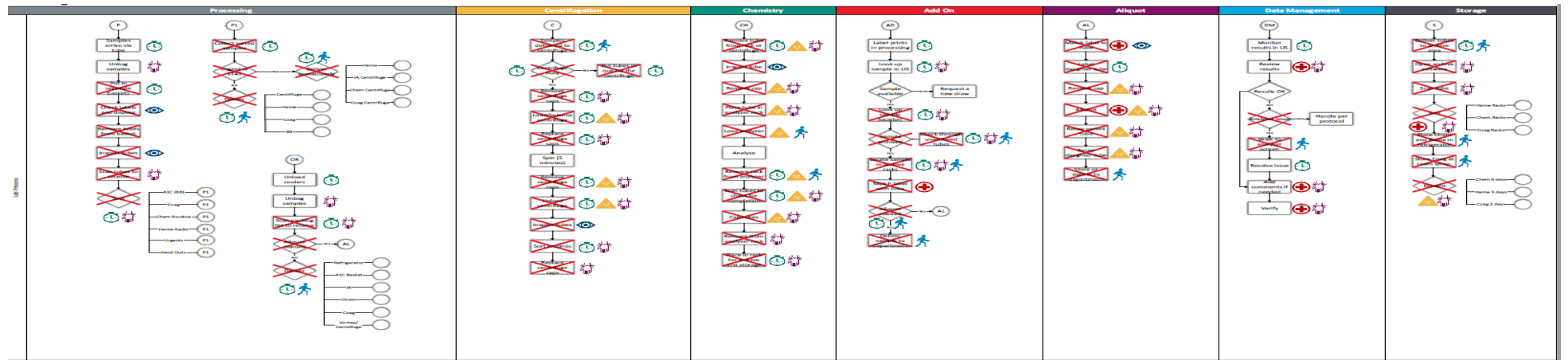
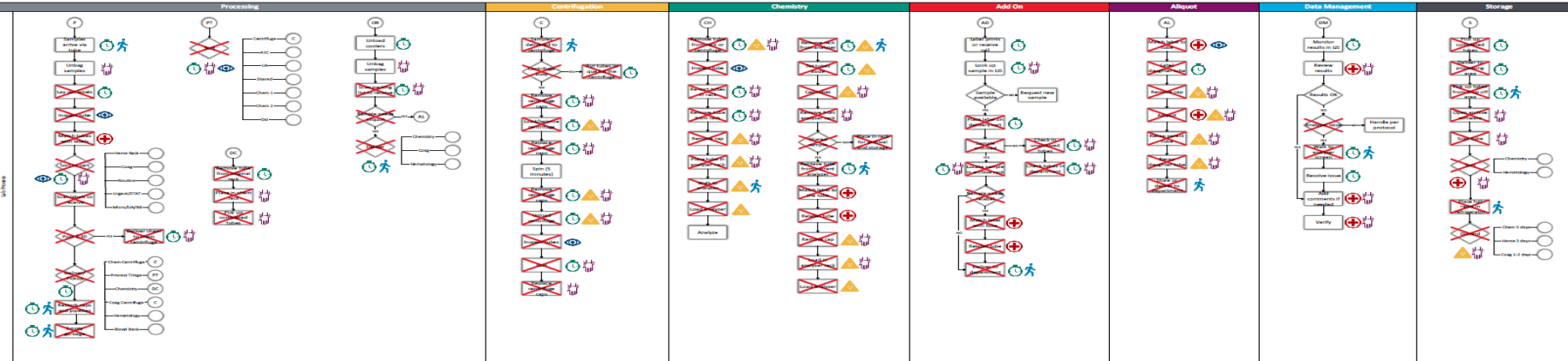

# Measuring Improvement (% change when automated workflow implemented)

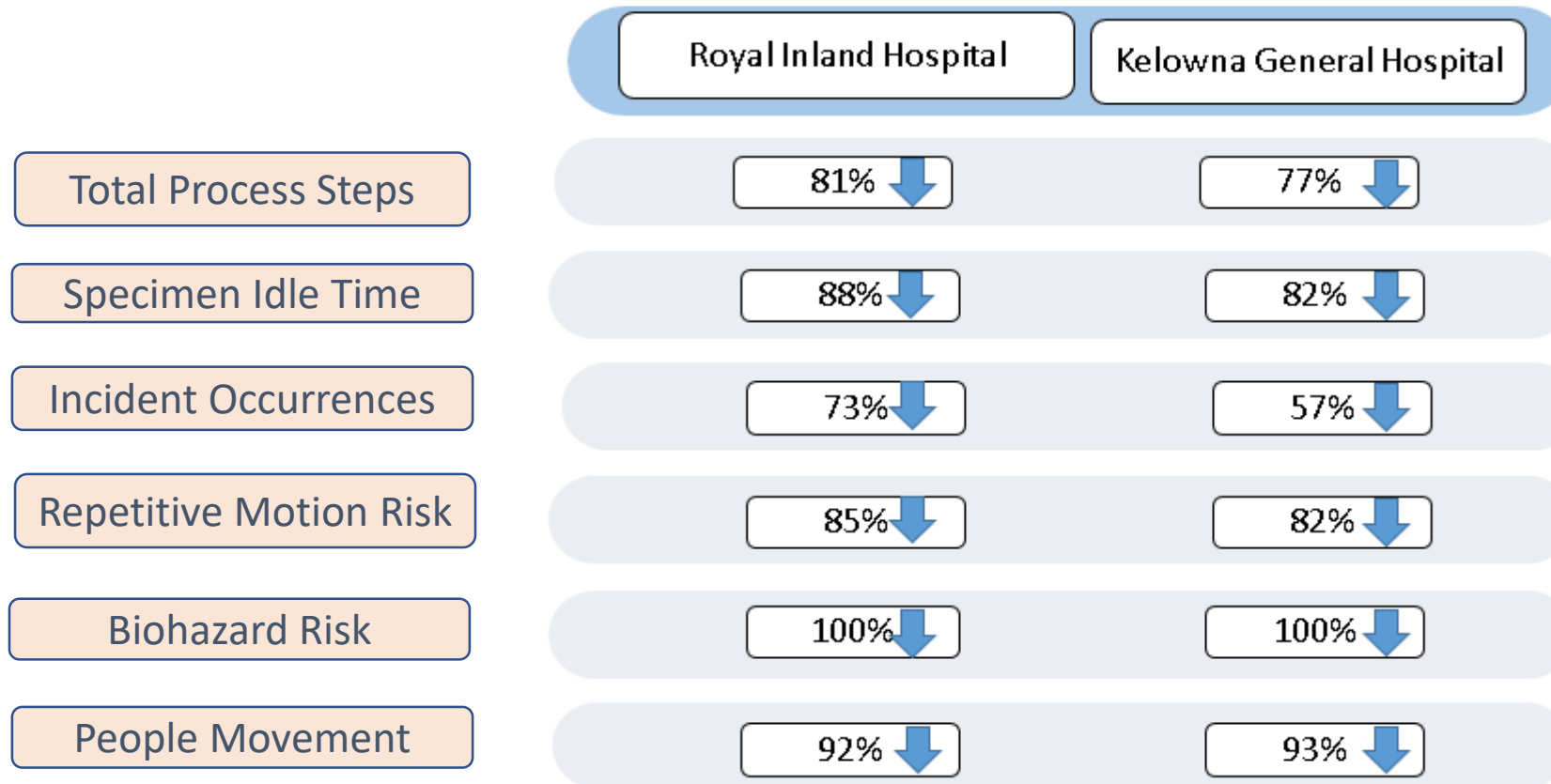



# Benefits of Automation and Middleware

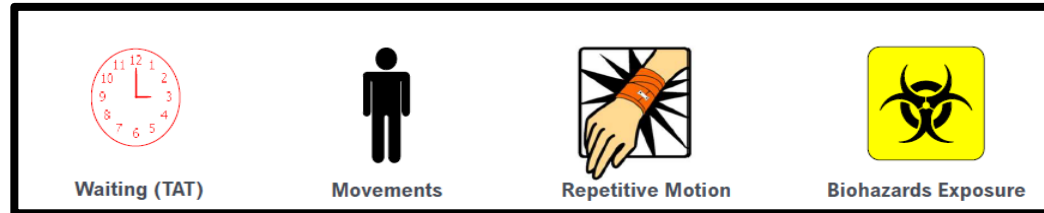

- Increases laboratory productivity. Staff can be redeployed to other areas of the laboratory
- Less blood needed from patients (less tubes required)
- Reduces test turn around times (may lead to improved care of critically ill patients)
- Improves consistency of turn around times (may improve patient flow e.g. in emergency department)
- Improves work safety by reducing risk of repetitive strain injuries and staff exposure
- Increases laboratory capacity (enables centralization of tests to larger hospitals)
- Enables current auto verification of results to expand from 60% to 95% (increases productivity, decreases turnaround times, etc.)
- Reduces human error
- Enhances central monitoring of Quality Control data from all hospital laboratories
- Allows for consistent quality across all sites and assists with troubleshooting
- Potential solution for reagent inventory management across all sites
- Enables highest quality test result



**THANK YOU**

